



MARKSCHEME

November 2012

DESIGN TECHNOLOGY

Standard Level

Paper 3

19 pages

*This markscheme is **confidential** and for the exclusive use of examiners in this examination session.*

*It is the property of the International Baccalaureate and must **not** be reproduced or distributed to any other person without the authorization of IB Assessment Centre.*

Subject Details: Design Technology SL Paper 3 Markscheme

Mark Allocation

Candidates are required to answer questions from **ONE** of the Options [1 x 30 marks].

Maximum total = [30 marks]

1. A markscheme often has more marking points than the total allows. This is intentional. Do **not** award more than the maximum marks allowed for part of a question.
2. Each marking point has a separate line and the end is shown by means of a semicolon (;).
3. An alternative answer or wording is indicated in the markscheme by a slash (/). Either wording can be accepted.
4. Words in brackets () in the markscheme are not necessary to gain the mark.
5. Words that are underlined are essential for the mark.
6. The order of marking points does not have to be as in the markscheme, unless stated otherwise.
7. If the candidate's answer has the same "meaning" or can be clearly interpreted as being of equivalent significance, detail and validity as that in the markscheme then award the mark. Where this point is considered to be particularly relevant in a question it is emphasized by **OWTTE** (or words to that effect).
8. Remember that many candidates are writing in a second language. Effective communication is more important than grammatical accuracy.
9. Occasionally, a part of a question may require an answer that is required for subsequent marking points. If an error is made in the first marking point then it should be penalized. However, if the incorrect answer is used correctly in subsequent marking points then **follow through** marks should be awarded. When marking, indicate this by adding **ECF** (error carried forward) on the script.
10. Do not penalize candidates for errors in units or significant figures, unless it is specifically referred to in the markscheme.

Option A: — Food science and technology

- A1.** (a) *Award [1] for stating one benefit of primary processing of wheat to produce white flour.*
removal of microorganisms and small insects;
enhanced shelf life;
better storage properties; **[1 max]**
- (b) *Award [1] for identifying one effect of excess carbohydrate intake and [1] for a brief explanation [2 max].*
excess carbohydrate converted to fat;
fat stored subcutaneously and around organs leads to overweight and obesity; **[2]**
- (c) *Award [1] for each of three distinct correct points in a discussion of how health awareness affects food choice in relation to fibre intake [3 max].*
low fibre intake can lead to a range of problems (*e.g.* increased gut transit times, raised cholesterol levels, haemorrhoids, colonic cancer);
health awareness would make people eat higher fibre diet;
selection of higher fibre foods, *e.g.* breads made from wholewheat not white flour; **[3]**
- A2.** (a) *Award [1] for a definition of food spoilage to the effect of:*
food becoming unfit for human consumption, for example due to chemical or biological contamination; **[1]**
- (b) *Award [1] for each of two distinct correct points in a description of the function of preservatives in food [2 max].*
preservatives preserve food by inhibiting the growth of bacteria and fungi on food;
they therefore enhance the shelf life of food; **[2]**

- A3.** (a) *Award [1] for listing each of two symptoms of nut allergy [2 max].*
mouth and lips tingling;
face swelling;
feeling sick;
urticaria (nettle rash or hives);
colicky pains in your abdomen (tummy or stomach);
a feeling of tightness around your throat;
wheezing or difficulty breathing due to an asthma-like attack, or swelling around your throat;
dilation of blood vessels which can cause skin redness of your skin, a fast heart rate and low blood pressure; **[2 max]**
- (b) *Award [1] for identifying one reason why the label offers information relating to nuts and [1] for a brief explanation [2 max].*
nut allergies are increasingly common;
potential consumers with nut allergies are looking for assurances about the likelihood of products containing nuts;
the company could be sued if “cannot guarantee nut free” is not included; **[2 max]**
- A4.** *Award [1] for identifying one issue relating to the scaling up of recipes from bench scale and [1] for a brief explanation [2 max].*
as production is increased the recipe may need to be modified to achieve same organoleptic characteristics – texture, etc;
e.g. more or less water in scaled up recipe; **[2]**
- A5.** *Award [1] for an example and [1] for each of two points of explanation of how chronic and acute food-related issues impact on a developed country’s health services [3 max] per issue, [6 max].*
Chronic food related issue:
e.g. diabetes / obesity;
long-term dependency on health services but not at acute level;
financial implications for public purse;
some of these problems are avoidable with increased levels of health awareness by the general public;
- Acute food related issue:*
e.g. food-poisoning incident in a hotel, restaurant or institution;
large numbers of people can be affected simultaneously;
short-term, potentially overwhelming, impact on health services; **[6 max]**

A6. Award [1] for each of three distinct points in an explanation of how each of three different corporate strategies have contributed to the development of the global brand of Coca-Cola® [3 max] for each factor [9 max].

market penetration;

strong marketing of product and use of event sponsorship, e.g. Olympics;

raise public awareness of product;

market development;

identification of new markets for products;

e.g. sports drinks / low calorie/lite products;

product development;

add variations to a product;

e.g. new flavours (e.g. cherry coke);

diversification;

bottling of water and other soft drinks;

exploit benefits of established brand;

[9 max]

Option B — Electronic product design

B1. (a) Award [1] for indicating the correct gate for X:
X = NOR ; [1]

(b) Award [1] for correctly stating what is used to convert an analogue signal to a digital signal and [1] for a description of how it works [2 max].
schmitt trigger;
switches to a digital signal when the analogue input voltage is above or below the switching threshold limits; [2]

(c) Award [1] each for correctly completing each column C, D and Q [3 max].

| A | B | C | D | Q |
|---|---|---|---|---|
| 0 | 0 | 1 | 0 | 0 |
| 0 | 1 | 0 | 0 | 1 |
| 1 | 0 | 0 | 0 | 1 |
| 1 | 1 | 0 | 1 | 0 |

[3 max]

B2. (a) Award [1] for correctly stating the function of a filter in a digital hearing aid.
to separate out different frequency bands;
a filter will allow the most common audio frequencies through to amplification;
a filter can prevent very low frequency noise/high frequency feedback from being too amplified; [1 max]

(b) Award [1] for stating one advantage of digital technology to the development of hearing aids in relation to amplification and [1] for a brief explanation [2 max].
can divide incoming sounds into distinct bands;
which can be individually selected for amplification;
the hearing aid can be tuned to individual needs;

multiple filters can be switched on or off to amplify those frequencies where the hearing loss is significant; [2 max]

B3. (a) Award [1] for each drawing of two resistors connected to the input A terminal of the operational amplifier and the power source.

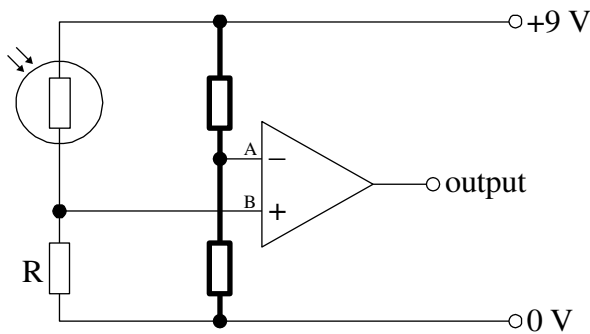

[2 max]

(b) Award [1] for identifying what would determine the upper extreme and [1] for identifying the lower extreme of the range of appropriate ratings for the components added in response to part (a) [2 max].

too high a value would affect the input impedance/current to the comparator / noise immunity of the reference input to the comparator would be compromised;
too low a value would flatten the battery/dissipate a lot of watts;

[2]

B4. Award [1] for each of two distinct points in a description of one limitation of open loop systems [2 max].

Lack of feedback;

It is not possible to determine if the system has done what is required/unable to respond to external influences;

[2]

B5. Award [1] for each of three distinct points in a discussion of two ways in which PIC technology can be regarded as sustainable [3 max] per way.

extends the life of a product;

reprogrammable/downloads software upgrades;

overcomes planned obsolescence;

materials;

reduction in number of components;

small volume of materials used to create the (silicon)chip;

energy;

low energy requirements for use;

reduction in energy requirements for manufacture;

disposal;

the (silicon) chip is non-toxic;

will not harm the environment;

suitable for re-use;

[6 max]

B6. Award [1] for stating each of three advantages of using optical fibre for transferring information in a communication system and [1] for each of two points of explanation [3 max] per advantage.

speed/bandwidth;

fibre optic networks operate at high speeds/large carrying capacity;

it can handle more data/serve more users;

no degradation of the signal;

signals can be transmitted further without needing to be refreshed/strengthened/
amplified;

the signal can travel further distances;

interference;

greater resistance to electromagnetic noise such as radios, motors or other nearby
cables;

higher quality signal;

maintenance;

thinner and lighter than copper cable;

fibre optic cables costs less to maintain;

high level of security;

EM radiation cannot be intercepted;

as with electrical signals;

[9 max]

Option C — CAD/CAM

- C1.** (a) *Award [1] for stating a suitable tool that could be used in a CNC router to machine the part shown in Figure C3.*
ball nose cutter; [1]
- (b) *Award [1] for each point in an outline of how the setting of the machine tool step-over variables will impact on the quality of the surface finish of the part shown in Figure C2.*
a low setting;
will give a smoother/more detailed surface finish; [2]
- (c) *Award [1] for each point in a discussion of the constraints of using a 3-axis machine for manufacturing the boat hull [3max].*
no allowance for any undercuts;
has a flat base/can only cut from above;
product has to be turned over to work on the underside; [3]
- C2.** (a) *Award [1] for stating an input device for a CAD system.*
scanner;
mouse;
graphics tablet;
3D scanner;
trackerball;
camera; [1 max]
- (b) *Award [1] for each point in an outline of one advantage of using finite element analysis (FEA) to design structures.*
shows the forces acting on a structure/object;
using a standard colour scheme to represent the stresses;

simulation;
no need to build the structure to test it;

provides information on any structural weaknesses of the design;
these can then be addressed by the designer;

uses data on structures/materials;
to inform further design decisions; [2 max]

- C3.** (a) *Award [1] for each point in an outline of **one** advantage of LOM as part of rapid prototyping.*
cost;
cheap materials can be used;
- size;
larger working area/base; **[2 max]**
- (b) *Award [1] for listing two benefits of being able to rapid prototype a product [2 max].*
small amount of waste due to the additive nature;
able to provide internal structure;
can produce a true 3D representation with no limiting factors;
no need for dust extraction system; **[2 max]**
- C4.** *Award [1] for each point in an outline of one reason why numerically controlled (NC) machines are still used in manufacturing systems [2max].*
still an appropriate technology;
e.g. used in carpet manufacture;
- capital/training costs;
expensive to replace with CNC machinery;
- tradition;
with some manufacturing systems, there is no impetus for change; **[2 max]**
- C5.** *Award [1] for each point in a discussion of two benefits of using CAM when manufacturing the ring in Figure C4 [3 max] per benefit.*
cost-effective;
once fixed costs are covered;
eliminates the need for expensive craft skills;
- type of design;
very intricate/detailed;
precision of CNC machining required;
- automated process;
variety of techniques;
integrated into one process;
- scale of production;
if popular with consumers;
can be easily produced in quantity; **[6 max]**

C6. Award [1] for each of three distinct points in a discussion of how the use of Haptic Technology aids the design and use of virtual training in relation to user observation, training and feedback [3 max] per aspect.

User observation:

enables the designer to observe the user's performance;
and the range of ways in which people interact with the product/system;
the designer uses this to improve the design of the product;

Training:

simulation;
dangerous/difficult situations;
e.g. bomb disposal/landing aircraft etc.;

Feedback:

sensors;
provide a wide variety of information to the user;
due to the sensitivity of the sensors;

[9 max]

Option D — Textiles

- D1.** (a) *Award [1] for one benefit for the manufacturer of using the fabric shown in Figure D1 in a car.*
can be cut to shape;
can join with other materials easily;
easy to fit in confined spaces;
cost-effective; **[1 max]**
- (b) *Award [1] for an advantage of the fabric being made by the technique of weaving and [1] for a brief explanation [2 max].*
dimensional stability;
it keeps its shape;

cost-effective technique;
easy to do;

high strength to weight ratio;
good tensile strength/lightweight;

if cut on the cross;
woven material will be able to be placed over complex curved surfaces; **[2 max]**
- (c) *Award [1] for a each distinct point in an explanation of why the fabric is woven from a fire retardant fibre rather than being treated. [3 max].*
the fabric will be exposed to extreme temperatures;
it needs to be fire retardant throughout not just on the surface;
otherwise the fabric may be set alight and therefore not perform appropriately; **[3]**
- D2.** (a) *Award [1] for stating the name of the substance that a silk worm creates to bind the threads when making a cocoon.*
sericin; **[1]**
- (b) *Award [1] for each clear point relating to why processing silk from silk worms is still a craft industry.*
difficult to automate or mechanise unwinding of silk cocoons;
no impetus to solve the problem/develop new technologies;

in some countries labour for craft production is cheap/easily available;
while machines are very expensive; **[2 max]**

- D3.** (a) *Award [1] for a distinct point and [1] for clarification of the point relating to one advantage to the consumer of textile labelling [2 max].*
shows care instructions;
so can determine cleaning costs prior to purchase/cleaning requirements after purchase/which domestic appliances can be used with the garment; [2]
- (b) *Award [1] for each correct point relating to one benefit to the manufacturer of using graphical images on the label [2 max].*
international symbols;
no linguistic interpretation;

global market for garments/cost-effective;
don't need different labels for different countries; [2 max]
- D4.** *Award [1] for a distinct point and [1] for clarification of point relating to one characteristic of Nylon that makes it suitable for tents [2 max].*
lightweight;
easy to carry;

low absorbency of moisture;
keeps dry inside;

durable;
able to cope with wear and tear/does not rot;

relatively cheap/readily available;
cost-effective for production;

easy to change the characteristics/properties;
for different types of tents; [2 max]
- D5.** *Award [1] for each distinct point in a discussion of two issues relating to the use of this type of packaging for the display of shirts in retail stores [3 max] per issue.*
environmental;
the plastic packaging will be discarded by consumers after purchase;
it could have a detrimental effect at disposal;

transparent material;
allows consumers to see the product;
but prevents consumers from handling and soiling the product;

consumers cannot feel the fabric;
often cannot see all of the labelling;
in order to decide if you want to purchase the shirt;

consumers cannot try the shirt on to test for fit;
without taking the shirt out of the package;
the shirt will not fit neatly back into the package; [6 max]

D6. Award [1] for each point in a discussion of three improvements of textile materials that enhance the performance of sportsmen/sportswomen [3 max] for each improvement.

development of Fastskin®;
which mimics sharks skin;
reduces drag/less resistance in water and therefore increases speed;

Lycra®;
tighter-fitting clothes;
therefore less wind resistance therefore more speed;

Lycra®/compression sportswear;
keeps muscles warm;
prevents muscle strain and fatigue;

Lycra®/compression sportswear;
wicks sweat away from body;
prevents chafing/skin problems;

Gore-tex®;
breathable fabric;
more comfortable clothes, less sweating, better performance;

3SP®;
warmth without bulk/enhanced breathability/stretch/wind-proofness/water repellence/comfort;
sportspersons in cold weather conditions can wear lighter/more flexible clothing;

physiological monitoring of sportspeople during exercise;
for example breathing rates / sweat monitoring;
can help to monitor training and ensure optimal performance;

DEFLEXION™;
can be used to make body armour;
protects sportsperson from high energy impacts;

swimsuits coated with nanoparticles;
repel water;
reduces drag;

[9 max]

Option E — Human factors design

- E1.** (a) *Award [1] for stating the reason for the position of the dishwasher in the kitchen layout.*
adjacent to the sink so easy access to plumbing; [1]
- (b) *Award [1] per distinct point in a description of the purpose of the use of a kitchen work triangle for the designer.*
to work out the optimum arrangement to position appliances for maximum safety and efficiency;
shortest distance to travel with hot containers/plates/meals; [2]
- (c) *Award [1] per distinct point in an explanation of how the work triangle can improve safety for users of the kitchen.*
sufficient circulation space allowed for using appliances;
considering the relationship between each appliance for use minimizes risk;
efficient arrangement reduces fatigue/number of journeys between each appliance for the user; [3]
- E2.** (a) *Award [1] for a definition of biomechanics to the effect of:*
the research and analysis of the mechanics of a living organism; [1]
- (b) *Award [1] per distinct point in a description of how biomechanics may affect the choice of a sample of people to be part in a user trial at the design development stage of a new type of can opener.*
a wide range of sample of users needs to be chosen;
in order to assess capability in relation to muscle strength/dexterity; [2]
- E3.** (a) *Award [1] per distinct point in a description of the function of the instrument in Figure E2.*
used to collect data relating to body parts;
the calipers measure the size of the parts e.g. hand size; [2]
- (b) *Award [1] per distinct point in an outline of one limitation of the use of the instrument in Figure E2 for collecting anthropometric data [2 max].*
difficult to collect very accurate data relating to body parts;
due to the amount of fat on people's body/amount of pressure applied may vary from person to person;
- people may be measured wearing clothes;
and the thickness of the clothes can vary from person to person; [2 max]

- E4.** *Award [1] per distinct point in a description of the purpose of conceptual testing to determine adequate product safety [2 max].*
evaluates the safety features of a product;
without exposing people to hazardous conditions; [2]
- E5.** *Award [1] for each distinct point in a suitable discussion relating to the impact of adjustability [3 max] and range of sizes [3 max] on the global market for clothing.*
range of sizes provided to appeal to a wide range of percentiles;
percentile ranges vary per user population in different regions of the world;
clothing sizes match these regional variations;

adjustability provided so users within a particular size range;
can adjust the item of clothing to obtain an individual fit;
e.g. the strap on a baseball cap; [6]
- E6.** *Award [1] for each distinct point in an explanation of why feedback, mapping and affordance are important in human factors design [3 max] for each aspect.*
feedback is the provision of information as a result of an action;
e.g. an audible or visual response to pressing a control;
so the user can decide how to respond;

mapping relates to the correspondence between the layout of controls;
and their required action;
e.g. making important controls most visible;

affordance is the characteristic of an object that indicates how it is to be used;
e.g. turning a control knob in the right direction;
to limit confusion and ensure safety/efficiency; [9]
-